



*St. Mark's Episcopal Church
Fincastle - Virginia*

Altar Guild Training Manual

For

Saint Mark's Episcopal Church
Fincastle, VA

ACKNOWLEDGEMENTS

Many thanks to each person, past, present and future, who has taken or will take part in this service for the Lord. Each person on the Altar Guild is a special person who has touched the lives of every member of St. Mark's as they've come to the Lord's Table.

Your time, hard work, sacrifices and dedication have prepared a place at the Table for many different people with many different needs throughout the years. Thank you!

It is a privilege to serve God in this way. We are humbled by the work we have to do so that others may partake of the Holy Eucharist.

Many thanks to Emily Moore, who has so graciously given us permission to update the instruction manual that she and others worked so hard on years ago.

Also thanks to all of the seasoned Guild members we have bombarded with questions, problems and changes who have so kindly lead us in the right direction.

We thank all of the present Altar Guild members who are so faithful and supportive. It is with your labor of love that St. Mark's continues to be beautifully adorned for every service and every season.

As we do our work, may we be reminded of why we come to the table.

“I have prepared a place for you says the Lord, that is for you and only you to fill. First of all come to My table and ask that you might serve, looking for even the lowest tasks, when the work of service is done, then you may look for your own place at the table. But do not seek the most important place in case it is reserved for someone else. The place I have appointed is where you will be the most joyous.” *(Taken from the Celtic Daily Prayer Book.)*

Mary Nicely and Sandy Stokes
The Co-chairs of the Altar Guild, June 2006

The following manual is a guide written for those who serve as members of the Altar Guild for St. Mark's Episcopal Church, Fincastle, VA. Each church and each priest has his/her own way of doing things, either from the past or current rectors, or simply from tradition of this church. If you have come from another Episcopal church, you may have done things differently than what you will be doing at St. Mark's. Its okay – the same things may be accomplished, just in a different way, not right or wrong, one place or the other.

Our Episcopal worship is Eucharistic-centered, and we follow the rubrics found in the Episcopal Book of Common Prayer (BCP).

The Rev. Irvin S. Mitchell tells us, “Only the servants of God, with the help of God, can do the work of the altar . . . Your scrubbing and polishing literally touches or is touched by each worshiper at the altar rail. You touch everyone in church that day with your love and dedication.”

The following pages will outline the preparations for the services from baptisms to burials. There are sections on laundering linens, cleaning and polishing brass and silver, arranging flowers and caring for the chancel and sacristy.

There are also Altar Guild manuals and information booklets in the sacristy available for your use. A checklist is provided for your use, either to follow as you are working or to look over at the completion of your duties. It can serve as a final reminder of the numerous small acts which are necessary to prepare the sanctuary for worship.

We hope that you will find joy in your service to fellow members of St. Mark's as you prepare for our corporate worship, and especially as you serve the Lord.

In preparing the Holy Table, we are preparing ourselves to receive God's gifts, and “because of this, service on the Altar Guild is a holy act. The washing of the linens, the care of the sacred vessels, the arranging of the flowers, all of this is sacramental in that it is an outer and visible sign of our love, our reverence, wonder and joy at the holiness of God . . .”¹_____

¹The Rt. Rev. Edmund L. Browning

Treasure your service as an Altar Guild member, and serve God devotedly, and lest you think there is all work and no levity, the following quote might indicate otherwise.

NINE COMMANDMENTS FOR ALTAR GUILDS

- If it's metal, polish it.
- If it's floral, arrange it.
- If it's cloth, iron it.
- If in doubt, wash it.
- If it has been taken care of by one person for more than ten years, avoid it.
- If it's a memorial, reverse it or try to work around it.
- If it's been done only one way for more than five years, don't try to change it.
- If new rectors, vicars, or curates get bright ideas, indulge them. They'll soon learn better.
- If a bishop wants all the vestments and hangings changed ten minutes before the service, smile sweetly, ask him to pray for a speedy recovery from your hearing loss, and leave him to his prayers in the solitude of the sacristy.

-- via St. Mary's Church, Madisonville, Kentucky

Every one of you has talents and gifts different from each other, but praise-worthy indeed. Use your abilities and develop new abilities in your service to God, the church, and those who worship at St. Mark's.

With gratitude and thanks to all St. Mark's Altar Guild members past, present and future!

FLOWERS

“Let the work of our hands be always acceptable in your sight . . .”²

The altar flowers should enhance the cross and never overpower it. The height of the arrangement should not exceed the arms of the cross. Only fresh flowers or greens are used in the church, never artificial ones. There are occasions when potted plants are used, but not on the altar.

Flowers are seen from varying distances – from those kneeling at the altar rail, and those sitting at the back of the church. Remember to evaluate your arrangements from both locations. Remember, too, that blue and purple flowers “fade” and appear to be holes from a distance. Yellow gives an openness and sunlit effect. Lighter flowers are often put at the top of the arrangement. Judiciously outline the arrangement with greens, or “spike” flowers. Cut stems different lengths to give depth. The presoaked oasis should be the focal point from which all the stems emanate.

There is information on flower arranging, books and sheets of helpful hints in the sacristy library. Flowers may come from the florist or from friends’ gardens, but Altar Guild members must arrange them. The brass vases are never to leave the church. The flower-filled baptismal ring may be taken home with the newly baptized child. The Guild member on duty is responsible for seeing that it is promptly returned.

Floral arrangements for weddings are kept simple, and floral displays at funeral services are placed in the narthex with discretion, using one or two arrangements.

Some members are concerned about arranging flowers, but few people dislike flowers, so let the flowers speak for themselves. Our Lord spoke of the beauty of the lilies of the field, which neither spin nor reap, “and yet even Solomon in all of his glory was not arrayed as one of these.”

²*Helpful Hints for Altar Flower Arranging* – workshop handout

FLOWERS (continued)

The task of the Altar Guild flower arranger is to help the flowers glorify God by following basic principles of flower design. Arranging flowers for the altar is a privilege, and should be done with humility and joy – and always to the glory of God. Remember that there is no such thing as “an ugly flower”. God has done the most important creation before you even begin the arrangement. Your task is to help His creations glorify Him.

And remember never to compare one person’s approach with another’s. Each person has different talents and a different aesthetic. Don’t invite frustration by unfair comparisons.

THE SACRISTY

The sacristy has always been a room or area in which the Eucharistic vessels and linens are kept and where prayerful preparations for the worship services are made. The preparations are done by the priest and a specially chosen group of dedicated people who comprise the Altar Guild.

When you enter the sacristy, remember that you are there to do the Lord's work, to make His house as beautiful as you can. Remember that you touch the whole congregation with your service as an Altar Guild member. Say a prayer quietly, or with your co-worker, that your service will be acceptable, in thanksgiving that you can serve, and whatever prayer is in your heart. Altar Guild members should be in the sacristy one-half hour before the service. It is the room that houses the sacraments, vessels, linens, and everything used for the Eucharist. Serve there with reverence, willingness and joy.

“Duty makes us do things well.

Love makes us do things beautifully.”

Phillips Brooks

The sacristy must be neat and clean at all times. All linens, vessels, etc. should be kept cleaned and polished, especially before the next Altar Guild team serves.

LINENS

The linens are all cared for by Altar Guild members. They are never sent to the professional cleaners. Only spotless, wrinkle-free linens are used. (The hangings, however, are sent to the cleaners. Wheelers Cleaners in Roanoke has beautifully cleaned them, free of charge, for a number of years.) Generally, soap and water are sufficient to launder all the linens, especially if stained ones are quickly rinsed in water. It is especially important to make sure that the linen is spotless before it is ironed. Strong bleaches cause the threads to weaken, and holes to appear more quickly. Wash linens and return them promptly. Take a difficult stain to the Altar Guild Chairperson.

The purificator is the smallest linen. It is used to clean the lip of the chalice during the Eucharist. It is a square folded right side out in thirds, then in thirds again with the design in the middle square. (See Figure 1)

Ironing the Purificator

This, too, is ironed and finger-folded into nine equal parts, right side to the outside, ending with the cross or, top. Remember, ironing in the folds wears linen.

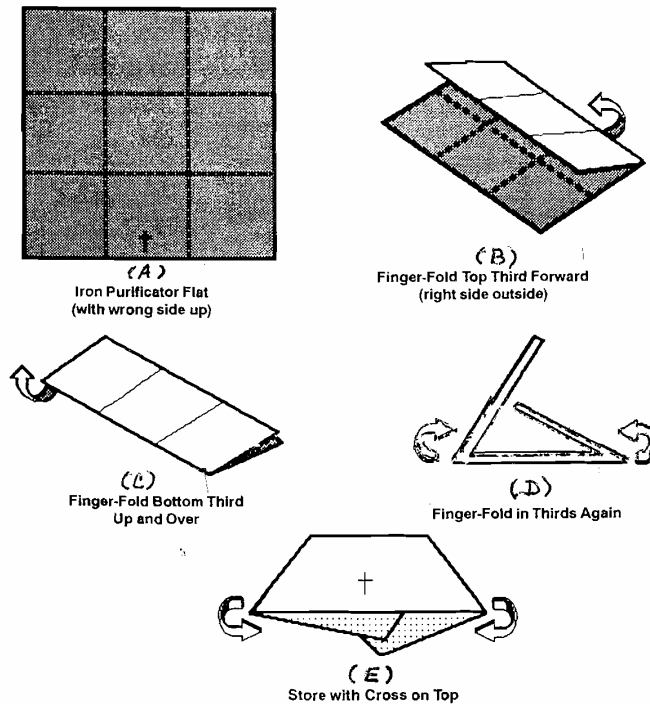
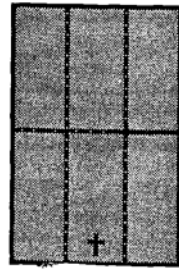

Figure 1

LINENS (Continued)

The rectangular baptismal and lavabo towels, that have the design at the bottom edge, are folded in thirds lengthwise, and then folded in half. (See Figure 2)

Ironing Lavabo and Baptismal Towels
Just fold into thirds lengthwise, the sides over the center, then in half.



(A)

Iron Lavabo and Baptismal Towels Flat

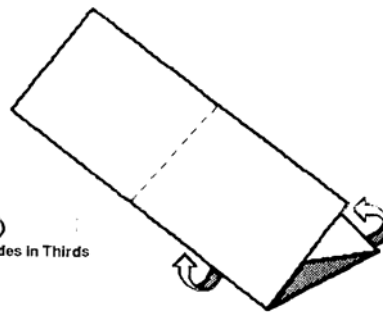

(B)

Finger-Fold Sides in Thirds

(C)
Finger-Fold In Half
and Store with Cross on Top

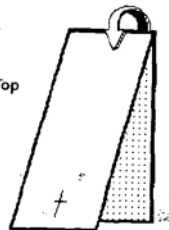

Figure 2

The corporal, with the design at the bottom edge, is folded inside out in thirds and in thirds again. This is so that when it is placed on the altar folded, it will be unfolded in correct position; and the corporal does not have to be turned or lifted once it is placed on the altar. (See Figure 3)

LINENS (Continued)

Ironing the Corporal

Iron the corporal flat, finishing with it right side up (see Figure 6-7a). Basically, you are going to fold it into nine equal squares. Ironing in the folds wears the linen. So, after ironing the corporal flat, simply finger-fold the top third toward you (see Figure 6-7b). The bottom third is finger-folded up and over the rest of the corporal (see Figure 6-7c). This makes it easy to find the cross and place it correctly on the altar. Finger-fold it in thirds again (see Figure 6-7d).

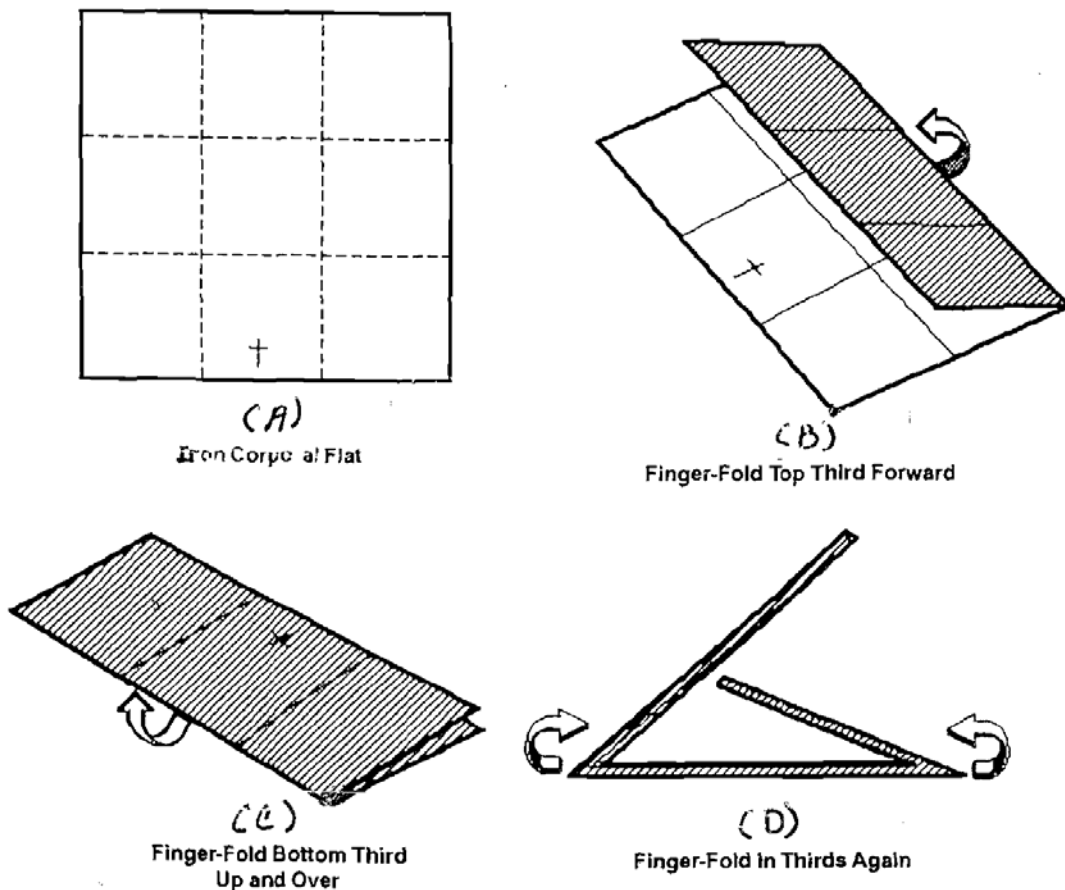

Figure 3

The pall is a stiffened, linen covered square that is placed over the paten to cover the host wafer. It is not regularly washed. (The “pall” is also the name given to the large covering for the casket, used always in place of flower sprays.) (See Figure 4)

LINENS (Continued)

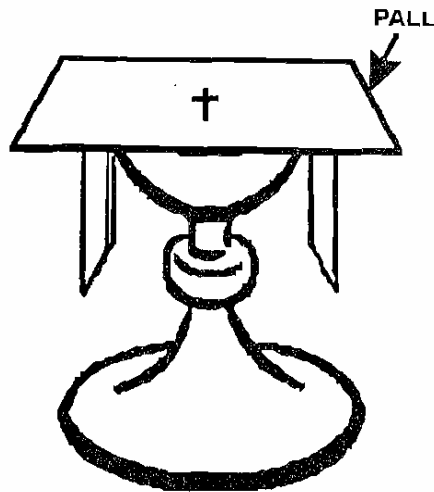

Figure 4

The fair linen is the longest and fairest linen on the altar, extending over the ends of the altar. It is usually embroidered with five crosses.

The Morning Prayer cloth, of thicker linen, is the size of the top of the altar. At the time of this writing, it may be used for services on the second and fourth Sundays and also services not involving the Eucharist. The fair linen is generally used on the first and third Sundays, but can be used without the Morning Prayer cloth for all Eucharist services. Three cloths are always on the altar when there are no services.

The dust cover, a remnant of the time when altars were not as protected and birds flew around the cathedrals, is a heavier cloth the size of the top of the altar. Ours is ecru. It covers the altar between services.

The back table cover is of heavier linen with a cross embroidered at the center edge. It is placed on the table by the baptismal font when the Eucharistic vessels are on the table.

All linens should be laundered and returned promptly. “Washing and ironing the linens can be such fun and is so rewarding. Snowy linens without spot or blemish are a joy to see.”³

³ Constance Murray Ribble

VESTING THE ALTAR

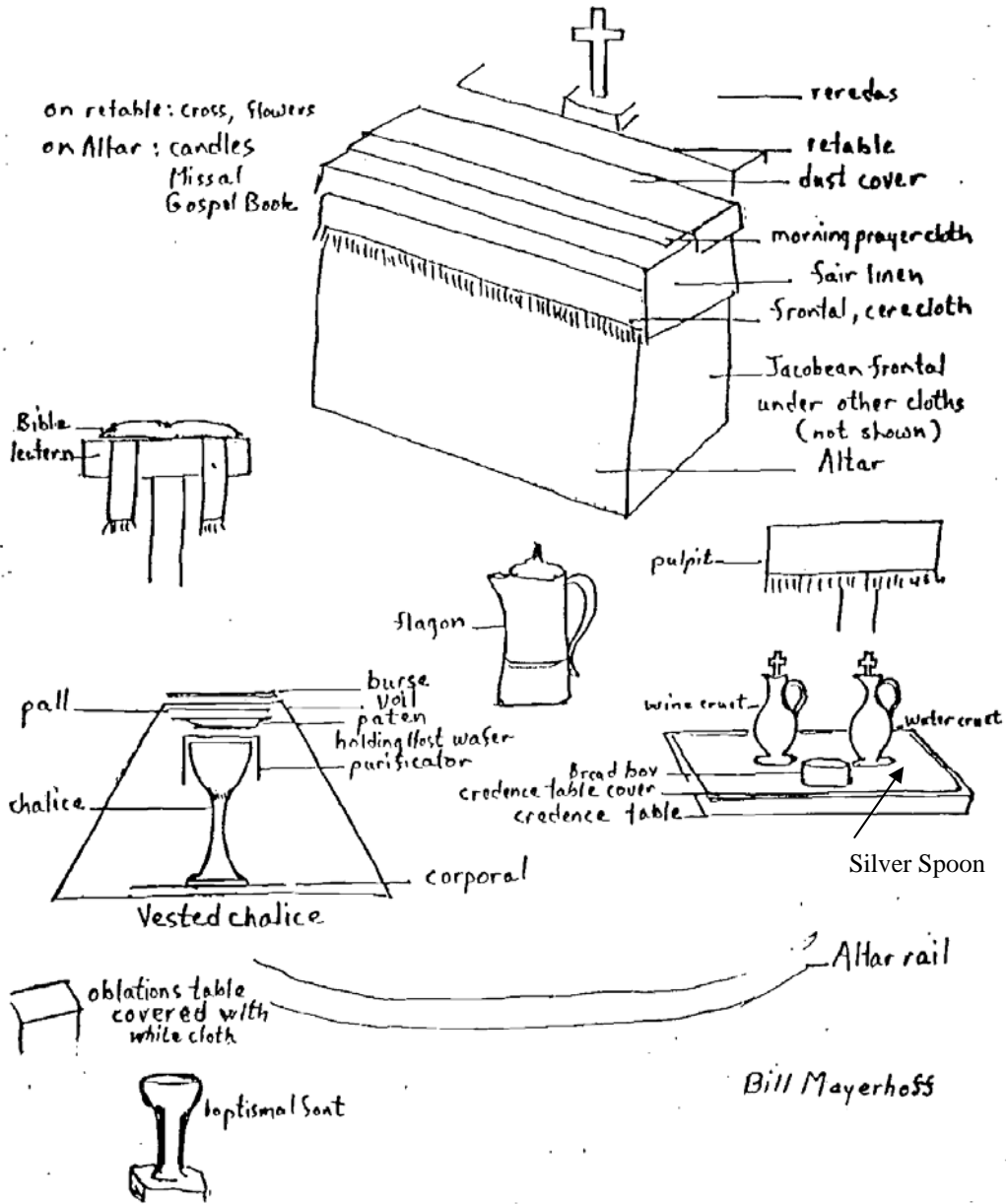

Figure 5

HANGINGS

St. Mark's has four sets of altar hangings. The different colors are used for the changing seasons of the church year, a part of the continuing tradition of the liturgical church. White is used for special festival occasions such as Christmas, Easter, Transfiguration, Trinity, Christ the King Sunday, weddings and funerals. Purple (a color which denotes penitence and also represents the royalty of Jesus Christ) is used during Advent, Lent, and also for funerals. During Holy Week, red is used on Palm Sunday, white on Maundy Thursday, and no hangings on Good Friday, when black is used to veil the crosses. There are also red veils and white veils for the crosses. The green hangings (green signifying the growth in our spiritual lives) are used first during the Epiphany Season and on the Sundays after Pentecost for the remainder of the church year (often called "the ordinary days."). Red (designating the saving blood of the Lord) is used for Pentecost, the Bishop's visits, and on specially designated Sundays, such as Saints' days. Refer to the liturgical calendar on the bulletin board in the sacristy for the proper color hangings for that day.

At St. Mark's sets of altar hangings include: the altar frontal, two markers for the Bible lectern and one covering the pulpit, the veil for the vested chalice, and the burse.

Our Jacobean frontal completely covers the front of the altar, and is used much of the year. It is not used during Advent, Lent, or the hot, damp days of summer. It is also removed for funerals. We have two funeral palls, one purple and one white.

ST MARK'S SILVER, BRASS, CRYSTAL AND TORCHES

At St. Mark's some of our communion vessels date back to the founding of our congregation in 1771 and are considered very precious. The silver vessels and items currently in use are the chalice (we have two), the flagon (or tankard), a large paten and a small paten, and a lidded box for the bread or wafers. It is always appropriate to set a silver spoon on the credence table when preparing for the Eucharist. The spoon is used in case crumbs or wafers are dropped accidentally in the chalice during communion. All communion silver should be washed, rinsed and carefully dried after each use.

There are two crystal cruets, one for water and one for wine. There is also a small cruet for sacramental oil. A small glass bowl holds extra wafers which are used at the 8 AM Eucharist.

The wooden collection plates [alms basins] are used at the 8 a.m. service. The brass collection plates [alms basins] are used at the 10:30 a.m. service. The brass collection plates will need less polishing if they are washed with hot, soapy water after each use. The crucifer's cross, the cross on the altar, the missal stand, the candle lighter, and small candle snuffer, the brass baptismal set, the candle holders, extenders and followers, and altar vases – all brass – should be checked before each use. Buff and polish when needed, but do not over-polish the silver or brass. If there is wax on brass items, heat the item with very hot water or the hair dryer and wipe with paper towels. Using a metal instrument to remove wax will leave scratches. The jewel-ornamented Gospel book should not be polished – just wiped carefully.

The hurricane lamps and glass candleholders are used for the Christmas season and sometimes for evening weddings. They should be stored clean and wax-free after they are used. The candles used on the altar are of a high percentage of beeswax, and are pillar type, not tapers. Two shorter candles may be connected with extenders, or ornamental brass tubes. Place followers on top of the candles; trim the candles when needed, then light the candles to make sure that they will light easily. Always straighten the wicks before a service.

SILVER, BRASS, CRYSTAL AND TORCHES (Continued)

The candles used in the hurricane lamps at Christmas are not beeswax altar candles. They are purchased each year and are generally tapered.

The advent wreath candles should also be pillar-shaped to accommodate the brass followers used on them. The large brass follower is used on the Christ candle and the Paschal candle. There is a wooden stand for these candles and the Advent wreath.

PREPARATION FOR A BAPTISM

The Rector will notify the Altar Guild chair when a liturgically proper date has been set for a baptism. This will usually be planned for a Sunday morning service or at the time of the Bishop's visitation.

1. The appointed Altar Guild member will make a banner for the person to be baptized.
2. Set up for Morning Prayer and Communion or Holy Eucharist if the baptism is to be combined with the regular worship service.
3. Polish, as necessary, the baptismal bowl insert for the font, the baptismal candlestick, ewer and small brass shell.
4. Put small candle in candle holder. (Keep the box so the candle may be taken home with the newly baptized.)
5. Put matches on back table.
6. Put linen cover on back table.
7. Put baptismal towel on back table near ewer, baptismal candlestick and small brass shell.
8. See that the baptismal banner (made for the person being baptized) is hung on the wall next to the heat/AC controls. (Hook is already there.)
9. Make the floral wreath (metal form is in the balcony on the cabinet) and place it on the font after removing its wooden cover and putting the brass insert in the font.
10. See that the back pew in front of the font is removed and put in the narthex. This is done preferably before Sunday or early that morning. Pliers (to loosen bolts holding pew to floor) are in the top right drawer in the sacristy.
11. White or Paschal candle in stand may be placed near the font.
12. Day of service fill ewer with warm water.
13. After the service, complete the duties as with Morning Prayer or Holy Eucharist.
14. Following the service double check to make certain that the baptized person (or parents) take home the banner, the candle, the baptismal towel, and the signed certificate of Baptism. Each of these items is to serve as a remembrance of this most important event in the life of the newly baptized member.

MORNING PRAYER AND COMMUNION

In the Sacristy:

1. Check all brass that might need cleaning or polishing. (Altar cross, processional cross, missal stand, alms basins [collection plates], vases, candlesticks – followers and extenders, and the candle lighter/snuffer.) Clean soot from snuffer. Replace candles when necessary. Also check snuffer on prayer desk.
2. Polish silver when necessary (chalice, paten, bread box). Wash them with hot water and soap after polishing; or instead of polishing, rinse and dry them thoroughly.
3. Never use hot water to wash the crystal cruets. Clean with vinegar occasionally.
4. Set up the vested chalice; see diagram on wall behind counter.
 - a. Chalice covered by purificator.
 - b. Paten placed on purificator.
 - c. Host wafer on paten.
 - d. Stiff white linen pall covers paten and host wafer.
 - e. Veil in the color of the church season is arranged over the pall to form the shape of a tent or tabernacle. The back of the veil may be folded over the top for ease of carrying to the altar, but should be lowered again (tent shape) when placed on the altar.
 - f. The burse, opening toward the back, containing an extra purificator, should be placed on top of the veil.
5.
 - a. Fill wine cruet with wine.
 - b. Fill water cruet with water.
 - c. Put wafers in bread box (include small piece of paper stating the number of wafers in the box).
6. Arrange flowers in the liners in the vase, noting the proper height of the arrangement – the top of the arrangement should not extend above the horizontal arms of the cross. The cross should be dominant, the flowers complementing it.
7. Leave sacristy clean, heat turned down, lights off, window closed, door locked, key in its place.

In the Sanctuary and Nave:

1. Remove the dust cover from the altar. Check to see that prayer cloth is clean and pressed. (No Gospel book and stand on second and fourth Sundays.)

MORNING PRAYER AND COMMUNION (Continued)

In the Sanctuary and Nave (Continued):

2. The hangings should be the correct color for the church season.
3. Place flowers on upper level retable behind the altar. Use plastic coasters under vases; check the height of the arrangement.
4. Place candlesticks on plastic coasters at the far side of the altar near the front. Make sure that the wick is exposed, that the candles will light, and that they are straight. (If Eucharist is not being served, the candles are always placed on the retable behind the altar.)
5. The wooden alms basins should be placed on the table beside the altar, behind the lectern (8 a.m. service).
6. Place Chasuble (correct color for each season) on the communion rail near the lectern.
7. Set up the hymn board, starting with the proper Sunday and church season post the hymn numbers and psalm number (stating pro. and rec.). The Sunday bulletin may be in the church office or in the narthex if it is not already in the sacristy.
8. The missal stand should be placed on the Epistle Side of the altar (facing altar, place to the left. The priest moves to the Gospel side after the reading of the Gospel).
9. Put credence table cover on credence table near altar. The silver spoon is placed on the Credence table
10. Make sure that there are matches or a lighter on the shelf under the lectern and on the shelf where the torches are secured.
11. See that the flags are straight.
12. Check the emblems on the altar front, vested chalice, and the hangings to be sure they are in line with the cross.
13. Flowers or potted plants may be put on the table in the narthex.
14. Flowers may be placed on small table at the top of the steps at the parking lot entrance of the church.
15. Prepare vested chalice as directed (see picture of vested chalice).

MORNING PRAYER AND COMMUNION (Continued)

16. Set the credence table with basin, towel, cruets, bread box, glass dish, and silver spoon (for 8 am service)
17. Check to make certain hand wipes and cough drops are available on shelf inside altar.

Day of Worship Service:

Before Service:

One-half hour before the worship service, turn on lights, raise shades in the Nave, and light Altar candles. Check flowers.

See Easter & Advent – If Christ Candle is used it should be lit by the altar guild member before the service begins and extinguished after the congregation leaves at the end of the service.

Check with lay reader to make sure the lectern Bible is marked for readings.

After the Service, and congregation has left the nave:

1. Put out flame on Paschal Candle.
2. Remove the vested chalice, cruets, bread box and fold corporal.
3. Remove flowers. Arrange for them to be taken to the sick or shut-ins when possible. Include a card and a bulletin so recipient knows who gave the flowers.
4. Place candlesticks on the retable (above altar).
5. Cover altar with dust cover.
6. Remove credence table cover.
7. See that alms basins are returned to sacristy. The offering, if not already collected, should be put in zippered bank pouch under counter in sacristy.
8. If any consecrated elements remain, they should be saved in the appropriate vessels and stored in the Tabernacle in order to be used in other services. If they are not saved, they should be reverently disposed of by consuming the consecrated wafers and any crumbs folded in the corporal, and the consecrated wine should be consumed or poured directly onto the ground.
9. Wash communion vessels, brass alms basins and cruets. Return them to the proper covers, put in cabinet and lock cabinet.

10. Check supplies of wine, bread and candles. If the supply is low, call it to the attention of the Altar Guild Chairperson.
11. Leave the sacristy clean.
12. Turn off lights, do not change the heat settings, close window, lock door and return key to its place.
13. Shades should be pulled down in the church. Doors to the narthex should be closed and front door locked and door to Parish Hall securely closed.

If there is a Healing Service on Monday the altar should be setup after the Sunday service.

HOLY EUCHARIST

Instructions are the same as those for Morning Prayer and Communion with the following exceptions:

1. Remove dust cover and prayer cloth. Check to see that fair linen is spotlessly clean and wrinkle-free before placing it on the altar.
2. The hangings should be the correct color for the church season.
3. The brass alms basins should be placed on the table beside the altar, behind the lectern.
4. The Gospel book in its stand should be placed on the Gospel side of the altar (pulpit side: facing the altar, to your right.)
5. Place the proper heavier linen cloth on the back table.
6. The credence table is set with water basin, towel, spoon. If the elements are to be carried forward by the laity, place the cruets and the breadbox at the back of the sanctuary on the table behind the baptismal font.
7. The candles are always on the altar for a service of Holy Eucharist. They are never ON the altar at any other time.

WEDDINGS

1. When the date for a wedding is set, the rector will notify the Altar Guild chairmen of the event, which should be noted on the sacristy calendar. Instructions will come from the rector or Altar Guild chairperson to those guild members on duty.
2. White hangings are used.
3. The altar flowers are arranged by an Altar Guild member only.
4. Hurricane lamps and candles may be used in the windows with fresh greenery and blossoms. The Bride and her mother will probably make these decisions and may consult with their florist and/or wedding coordinator concerning such arrangements. Altar Guild members on duty should assist as appropriate, but not attempt to dominate or dictate these decisions.
5. A suitable arrangement of flowers may be used in the narthex.
6. Branch candelabra may be used inside the altar rail.
7. The wedding pillow should be clean and available. It is located in the cabinet in the balcony.
8. Ribbons or silken ropes are permitted on pews to reserve for family members.
9. Check with the Rector to be sure that the Parish Register is available for the Bride, Groom, maid of honor, and best man to sign, following the ceremony.
10. After the bridal party has departed from the church, (after all the photographs have been taken, etc.) clean up the sanctuary and prepare for the next service of worship, changing the altar hangings as necessary. It is the Bridal party's responsibility to pay for the sexton to clean the entire church after the party has left the church premises. It is the responsibility of the Altar Guild only to prepare the sanctuary and nave for the next service. The sextons will vacuum. The Altar flowers are always to be left for that service, as a reminder to the whole congregation that the sacrament of marriage has occurred here.

NUPTIAL EUCHARIST

1. Prepare altar as for Holy Communion (consult with the rector).
2. Place a small table with white cloth for elements near the altar rail. (Consult with the rector for the location of table and the placement of the communion vessels to be used.
3. Check with the rector concerning the number of people participating in the Eucharist.

After the service:

1. Complete the duties as with Morning Prayer or Holy Eucharist.
2. Change hangings to seasonal color.

The following two pages are St Mark's current guidelines for weddings. They are to be discussed with the wedding party by the Rector (only). The Rector will provide the Altar Guild with guidance on our specific responsibilities. Please do not confuse matters by taking direction from members of the wedding party.

GUIDELINES FOR WEDDINGS
St. Mark's Episcopal Church
Fincastle, Virginia

So you want to get married! How wonderful that you have found a love to which you wish to commit for the rest of your lives! St. Mark's wants to support your love and commitment to one another, but as the church of Jesus Christ we have responsibilities to God and to one another in this support. The following guidelines have been prepared by the Vestry to aid you in your planning.

1. Date for the wedding and for the rehearsal will be set with the Rector who will explain the canonical guidelines for weddings in the Episcopal Church to the couple and complete required counseling sessions. **The Rector will have the final say on all arrangements relating to the marriage ceremony, including the music to be used in weddings.** This includes arrangements made with or through a guest priest.

2. Marriage for members of St. Mark's who have met the canonical requirements of the Episcopal Church. There will be no charged fees required for the use of the church building or the services of the Rector, however the bridal party will be responsible for the sexton's fees and the organist's fee as well as any gifts to those musicians who will be providing special music. As members or as children of members of St. Marks, the bridal couple should understand the sacramental nature of the marriage service in the Episcopal Church. As a part of their membership in the Church of Jesus Christ they will be asked to consider tithing 10 percent of the total cost of the wedding festivities to St. Mark's, in order to begin their lives together in Christ, offering the "first fruits" of their lives to God.

3. Should the rector agree to marrying a couple who are not members of St. Mark's, the Vestry will charge a use fee for the church facilities which is to be sent to the Treasurer of St. Mark's, P.O. Box 277, Fincastle, VA 24090 two weeks prior to the wedding. Make checks payable to St. Mark's Episcopal Church.

Use fees for non-members:	Sanctuary	\$300.00
	Use of all facilities	\$425.00
	Organist (to be arranged with musician)	
	Sexton	(Approx) \$100.00
	Rector's Honorarium (only applicable to non-members, and should be made as a gift to the St. Mark's Discretionary Fund)	

4. *Once a date has been set for the wedding, the rector will ask that a Head Usher serve as Verger for the ceremony. The rector will also notify the sexton in order to coordinate the date and time for cleaning.*

5. The following will be expected of the wedding party:

A. Please do not change the setting of the air conditioning or heating. Make arrangements with the Verger to do so.

B. All areas of the church and grounds must be left clean and tidy. Should St. Mark's sexton be unavailable to clean the area, it will be the responsibility of the bridal party to hire someone else for cleaning which shall be given a final check by the Verger. Because of the multi uses of St. Mark's, it may be necessary to arrange for the Sexton's services both before and after the service.

C. St. Mark's has a policy of NO birdseed, rice, confetti, or petals thrown in or around the church. One possible exception to this rule: when a flower girl is to distribute rose petals, a runner will be required to be provided by the bridal party.

D. Please notify the Altar Guild Chairperson so that arrangements can be made for the ceremony, including hangings, Eucharistic vessels, and flowers. The Altar Guild must oversee the flower arrangements by your florist for the sanctuary. The Altar Guild, at your request, will arrange the flowers for the cross shelf only. Any flowers placed on the cross shelf are considered a gift and remain in the church. You are responsible for the expense of all flowers used. The vases used on the cross shelf may not be taken from the church!

E. **NO FLASH** pictures may be taken during the ceremony. Video cameras may be used only from the gallery and the back of the sanctuary. Should the wedding party desire that formal wedding photographs be taken in the sanctuary before or following the ceremony, these should be done only when there are no other guests in the sanctuary.

F. Because this is a church service with liturgy, you may desire a printed program or bulletin for the wedding. The Rector must give final approval of the copy for such a bulletin prior to its printing and distribution. Copies will be made available for the rehearsal. Included in your information to wedding guests should be the admonition that NO FLASH PICTURES are to be taken within the church sanctuary during the service.

G. All areas of the building will be available for the use of the wedding party with the exception of the choir room. This means that the church phone is available only through the Verger. It is suggested that the bride and bridesmaids use the downstairs Parish Hall as a dressing room and the gentlemen use the nursery/former library area.

Your wedding day should be one of the most memorable and happy days of your lifetime! It is St. Mark's desire as a congregation to help you start your new life together with God in joy and thanksgiving and respect for one another and His Church. Feel free to discuss these guidelines with the Rector.

Rector: The Reverend Ann D. Kruger (church) 540-473-2370, (home) 540-992-5141

Parish Organist: Tommy Hunter, 540-884-2433

Altar Guild Chair: Mary Nicely, 540-473-3402 and Sandy Stokes, 540-473-3205

Junior Warden: Jay Gordon, (540) 992-4092

Head Usher: Mel Carico

Sexton: Peggy Dunbar, 540-992-5476

(Rev. 10/20/04)

FUNERALS

1. May remove Jacobean frontal if it is in use.
2. Hangings are white unless instructed otherwise. Use the casket pall when casket is present.
3. The family should be consulted about the altar flowers. If they do not wish to purchase them, the Altar Guild will furnish them.
4. Flowers may be placed in narthex if used with discretion.
5. Flower arrangements (except on the altar) are not used in the nave or sanctuary.
6. The pall should be available in order that the casket can be covered before it is taken into the nave. (It may be given to the funeral director beforehand. The pall should be returned to the Altar Guild member as the casket leaves the church unless other arrangements have been made beforehand. May be used by the family at the funeral home.)
7. Flowers are never placed on the pall.

A REQUIEM

1. Check with the rector for instructions. The rector will see that the pall is given to the funeral director and is returned to the church.
2. If a Eucharist is requested, see the section on Eucharist altar preparation. Use white hangings. Provide enough wafers for entire congregation (200).

ADVENT (4 Sundays before Christmas)

1. Remove the Jacobean frontal.
2. Place Advent wreath on the wooden stand inside the altar rail on the Epistle side.
3. The wreath has three purple candles and one rose candle, and a purple bow.
4. A large white Christ candle is in the center and followers are placed on all the candles..
5. Use purple hangings. (May use blue if available.)
6. Arrangements of greens have traditionally been used on the altar; some berries are considered appropriate. Wreaths of greens are appropriate on the front door adorned by purple bows throughout Advent. Bows should be changed to red or white for the Christmas Eve services.

PREPARATIONS FOR CHRISTMAS

1. Prepare the altar as for the Holy Eucharist. There are special linens for the vested chalice in the Christmas season.
2. After the service, complete the duties as with the aforementioned services.
3. Garlands are made of running cedar tied together with fine green wire or green string.
4. Wreaths are made of hemlock. Red bows are placed at the center bottom of each wreath. There are seven cardboard forms to be used in making the wreaths.
5. Wreaths for the door may be made of running cedar, white pine or boxwood. Red bows are placed at the center bottom, not top. Use straw wreath forms.
6. All wreath forms and bows are stored in the cabinet upstairs in the balcony.
7. Hurricane lamps with candles and greenery are used for the windows. They are stored in the balcony. Check the number of available candles for the Christmas Eve services ahead of time.
8. Cut Poinsettias or other suitable flowers are used on the altar. Poinsettias in pots may be placed inside the altar rail and in the windows of the nave at the discretion of the Altar Guild workers. They are also placed in a suitable manner in the narthex.
9. White hangings are used. The Jacobean frontal is placed on the altar.
10. The candles in the Advent wreath are changed to white with, the large white Christ candle placed in the center. Put followers on all the candles. The purple bow is exchanged for a white one. The purple and rose Advent candles may be left through the Christmas season. The Christ candle is not lit until the Christmas Eve services
11. The St. Mark's Altar cloth is used on the altar and the Christmas linens (corporal, Purificator, etc) are used for the vested chalice.
12. The garlands and wreaths are placed in the church after the last service in Advent and are removed the 6th day of January – Epiphany, or after Twelfth Night Celebration.
13. Check number of candles for the candle light service and place in baskets at the back of the church.

EPIPHANY (1st Sunday after Jan. 6th)

1. Green hangings are used
2. Use the white Christ Candle throughout the Easter Season
3. Epiphany is also a time for Baptisms and Blessing of Homes

ASH WEDNESDAY

1. Remove Jacobean frontal and flags.
2. The hangings are purple.
3. Check with the rector concerning instructions for the communion service and imposition of ashes. (Check beforehand that the ashes are on hand.)
4. An arrangement of greenery may be used.
5. Prepare the communion vessels as for any service of Holy Eucharist.
6. After the service, complete the duties as with the aforementioned services.

The palms from Palm Sunday service are burned and ashes are used for this service – palms should be ordered every year in November.

LENT

1. Purple hangings are used.
2. Greenery might be used on the altar on the latter Sundays during Lent.
3. The processional cross may be veiled throughout the Lenten season with purple or black.
4. Palms are used for the altar arrangement

PALM SUNDAY

1. The hangings are red.
2. Palms are used for the altar arrangement and may include appropriate greens and some spring flowers. The same can be used in the narthex.
3. Veil the altar cross and the processional cross in red.
4. Palms to be carried by the congregation should be available. Check with the rector concerning the distribution. Trim to remove dried tips. Save the used palms for next year's Ash Wednesday ashes.
5. Prepare for Holy Eucharist. Use Palm Sunday linens for the vested chalice.
6. After the services, complete the duties as with the aforementioned services.

MAUNDY THURSDAY

1. Hangings are white.
2. Before service remove the flags.
2. White flowers and/or greenery may be used on the altar.
3. Veil the altar cross and processional cross in white.
4. Prepare for Holy Eucharist.
5. Check with the rector concerning the service and prepare for the ceremonial washing of feet if this is to be included in the service. (Have towels, wash bowl, 2 chairs, and pitchers of warm water available. Pitches filled with warm water should be placed next to the basins before the service.)
6. The Altar Guild members assist in stripping the altar after the service.
7. The small wooden cross, unveiled, should be in the sacristy and carried into the church after the altar is bare. The large wooden cross to be flowered is kept in the balcony.
8. The large wooden cross, also used for the flowering cross Easter Day, may be placed in the narthex and draped with a black cloth. (Cloth is in upper cabinet in sacristy; wooden cross is kept in balcony.)
9. For the stripping of the altar, all members of the Altar Guild should be on hand to receive the various items from the sanctuary and place them in their proper places in the sanctuary. As members of the congregation come forward to receive each of the items to be stripped, Altar Guild members should be located at the back of the nave to receive each item, pass it on to another Altar Guild member who in turn passes it to the two members in the Sacristy who put it away. This reverent ceremony can best be achieved with a basic organizational plan.

GOOD FRIDAY

1. The wooden cross bearing the crown of thorns is placed in the sanctuary and can be draped. The processional cross is veiled in black. The processional cross is placed in its holder in the sanctuary.
2. The wooden collection plates are placed on the back pew aisle seats.
3. Check with the rector for any additional instructions for the service.

TENEBRAE SERVICE (Wednesday night)

1. A candelabra (to be rented) may be placed inside the altar rail. Single candle holders (the number corresponding to the number of readings made) can also be lined across the altar.
2. The Paschal candle stand, with plain white Christ candle, is placed near the lectern and candelabra.
3. See that all candles are lit before the service.
4. Place candle snuffer on lectern.
5. Check with the rector concerning the dimming of lights during the service.
6. Put reading light on lectern. (stored in the hall cleaning closet)

EASTER DAY

1. Use white hangings and the Jacobean frontal.
2. The altar arrangement will include lilies, spring flowers and the Paschal candle.
3. Potted lilies, or other flowers, are placed in the windows and in the narthex, in addition to a floral arrangement on the narthex table and on the hall table
4. Place the wooden flowering cross outside the altar rail near the lectern.
5. Place the flags in the sanctuary on either side of the altar. (The American flag is on the Epistle side, the Christian flag on the Gospel side.)
6. Replace the white Christ candle with the Paschal candle into which the five red wax nails have been inserted. (Check year number on candle.) Put brass follower on candle.
7. The Paschal candle should be lit by the Altar Guild members one-half hour before the service and extinguished by the Altar Guild members after everyone has left the nave.
8. Use Easter linens for the vested chalice.
9. Prepare for Holy Eucharist.
11. After the service, complete the duties as with the aforementioned services.

PENTECOST

1. Hangings are red.
2. The majority of flowers in the altar flowers are red.

ASCENSION

1. After the service, remove Paschal candle and stand.

BISHOP'S VISIT

1. The hangings are Red
2. The flowers are red and white
3. The Bishop's chair is placed in the sanctuary on the Gospel side of the altar
4. Check with the Rector concerning any special requirements for Confirmation or Baptism

HEALING EUCHARISTS and other week day Eucharist

1. Hangings are those for the church season
2. Flowers (at the consent of the donor) can be left from the preceding Sunday
3. Consecrated sacrament will be used in most instances (the exception being for an Intergenerational Eucharist, in which case provision should be made for a full Eucharist with host in place.)
4. Set the credence table with lavabo, towel, water cruet and spoon. Remove wine and bread box from the tabernacle and place on the corporal.
5. Set the table with vested chalice, but no host wafer.

FOR VISITING PRIESTS

1. Be there early! Greet the visiting priest in the sacristy, identify yourself as the Altar Guild members on duty, and make yourself available to their requests of you (glass of water, etc).
2. Show him/her the prepared table; point out the counted wafers in the glass dish for the 8AM service and the breadbox with counted wafers for the 10:30 AM service. Show him/her where the chasuble is placed.
3. In the sacristy show the priest the “red book” church registry, which will require his/her signature and a count of those in attendance and of those who communed – ushers should take care of counting attendance and provide priest with the count.
4. After the priest has seen everything—the layout, the strange “gospel side”, the credence tables, etc., ask again if he/she has any special needs or request. Some may really want a glass of water available, others may have forgotten a stole or have some other last minute request. Your job is to be a servant.
5. Following the service remind the priest to sign the church register, and add the count.

GLOSSARY OF TERMS

These are some of the items associated with our worship service, and which are under the care of the Altar Guild members. Information on history, usage and symbolism is in books in the sacristy and the library.

<i>Bread Box</i>	(Called “ciborium” if footed) holds the bread before it is consecrated
<i>Burse</i>	The fabric-covered case on vested chalice; holds extra purificator
<i>Candles</i>	Used on altar, other areas of chancel and sanctuary
<i>Cere Cloth</i>	Cloth used next to the altar to protect white linens
<i>Chalice</i>	Cup used to administer the wine
<i>Chancel</i>	Raised area of church surrounding altar
<i>Chasuble</i>	Celebrants garment worn for administering communion.
<i>Corporal</i>	Linen placed under vested chalice; catches crumbs in wine
<i>Credence Table</i>	Holds wine, bread and water before they are consecrated
<i>Cruets</i>	The vessels which contain the water and wine
<i>Dust Cover</i>	Covers altar when worship services are not in progress
<i>Extenders</i>	Brass connector that joins two shorter candles
<i>Fair Linen</i>	finest linen covering the altar, over the cere cloth
<i>Flagon</i>	The vessel used to hold the wine to fill the chalice
<i>Flowers</i>	Placed on retable; they signify the Resurrection
<i>Followers</i>	Brass top for candles
<i>Frontal</i>	(Supra-frontal) in church seasons’ colors, used as cere cloth under linens
<i>Gospel Book</i>	gold book placed on the altar for the 10:30 service and “high” church services
<i>Hangings</i>	Fabric of the church seasons’ colors; for altar, pulpit, lectern
<i>Jacobean Frontal</i>	Ornately designed fabric covering entire front of altar

GLOSSARY OF TERMS (Continued)

<i>Missal</i>	Contains the service of the Eucharist in all its variations. It also contains music for conducting a sung Eucharist. It is always placed on the altar
<i>Morning Prayer Cloth</i>	Covers fair linen, used for services other than the Eucharist
<i>Pall</i>	Linen-covered “plate” that covers the paten bearing the Host wafer [another meaning – the fabric covering the coffin]
<i>Paten</i>	Plate used to hold the Host wafer
<i>Purificator</i>	Linen used to clean the chalice during the Eucharist
<i>Reredas</i>	Panel behind the altar
<i>Retable</i>	Raised table behind altar (shelf)
<i>Sacristy</i>	The room or area where altar linens and vessels are kept
<i>Torches</i>	Candle holders that are affixed to a staff. They come in pairs. There may be two, four or six for a service.
<i>Veil</i>	The fabric covering the vested chalice; arranged to resemble a tent

ST. MARK'S EPISCOPAL CHURCH
ALTAR GUILD CHECKLIST

In the Sacristy:

1. Check bulletin for type of service (Morning Prayer or Eucharist Rite II)
2. Check calendar for correct color of hangings
3. Count wafers: 30 in small glass bowl
40 loose in bread box
40 in plastic bag in bread box
4. Pour water and wine in cruets (just past bottom of handle).
5. Lavabo bowl and towel, small white square table cover
6. Vested chalice
7. Wooden plates for 8 a.m. service
Brass plates for 10:30 a.m. service
8. Polish brass when necessary
9. Press cloths when necessary
10. Check torches for oil and check cross
11. Check candle lighter/snuffer for sufficient wick and ease in lighting.
12. Do flowers for [a] Altar
[b] Narthex
[c] Back table in back hall

In the Sanctuary:

1. Set back table on the 1st, 3rd and 5th Sundays (unless otherwise instructed)
2. List hymns and Psalm numbers on the board
3. Mark Lector's book and the Gospel book (put readings in the Gospel book and in the Bible for the Lector)
4. Set the credence table (water, wine, wafers, spoon, lavabo bowl with towel; wine closest to the altar, and glass bowl with wafers)
5. Set the altar (Gospel book for the 1st, 3rd and 5th Sundays. Find 3 people to bring the sacraments to the altar before the 10:30 service.) – Missal on left and Gospel book on right.
6. Light candles to test the wicks (length and wicks)
7. Check for correct plates
8. Put correct color chasuble over rail
9. Turn off lights, close blinds, and lock doors if outside doors opened
10. Clean sacristy

After Sunday Service:

1. Close blinds
2. Check all candles to make sure they're out
3. Wash and clean all vessels and leave sacristy clean and neat
4. Collect linens to be washed.
5. Turn off all lights and lock all doors.